

# VoxGuard VU™

## USER GUIDE

Congratulations on purchasing the Primacoustic VoxGuard VU! The VoxGuard VU is a near field vocal screen designed to reduce the ambiance around a microphone when recording voice. Please take a few minutes to read through this manual. It includes a list of parts as well as step by step mounting instructions. Please refer to [www.primacoustic.com](http://www.primacoustic.com) for various placement options, benefits, and general room acoustic information. Should you have any questions or comments, we invite you to send us an email at [info@primacoustic.com](mailto:info@primacoustic.com).

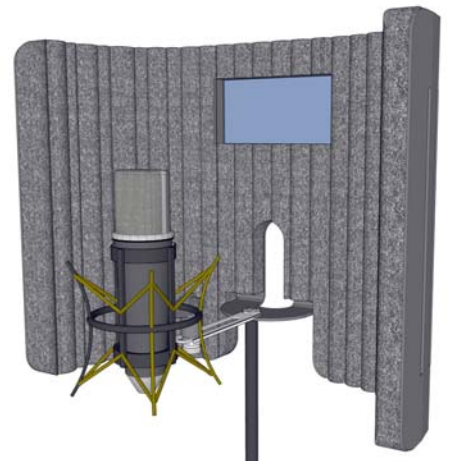

### SIDE ADDRESS STUDIO MICROPHONE\*

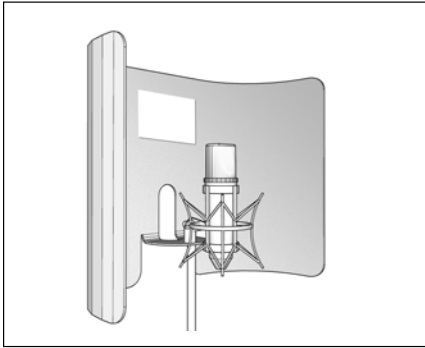

### FRONT ADDRESS MICROPHONE\*



### STUDIO MIC WITH LARGE BOOM EXTENSION\*

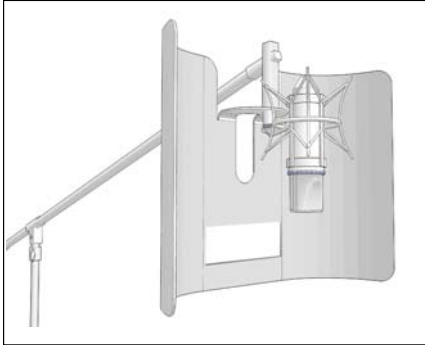

\*Microphones and stands not included.

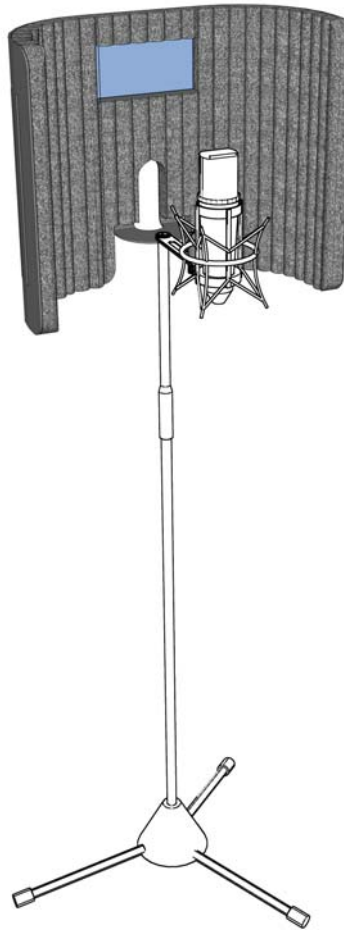

### BOX CONTENTS:

Before beginning assembly, please take a moment to familiarize yourself with the box contents.

VoxGuard VU

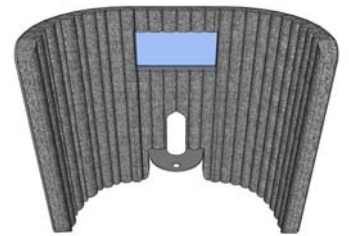

Knurled Ring



Threaded Thumbscrew with Insert



Extension Bar

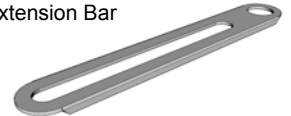

### LIMITED WARRANTY

Primacoustic products are guaranteed to be free of manufacturing defects for a period of thirty (30) days after purchase. In the unlikely event that a defect is uncovered, please email [info@primacoustic.com](mailto:info@primacoustic.com) or call 604-942-1001 to obtain a return authorization number (RA#) from Primacoustic before the thirty (30) day warranty period expires. Once you have obtained an RA number return the product, freight prepaid, within fifteen (15) days after the date the RA number is issued. In the original packaging (or another, affording an equal degree of protection) include all of the following: (1) RA number clearly marked on the returned package; (2) a copy of the original bill of sale showing proof of purchase from an authorized retail seller; and (3) a written note describing the defect including your name, address, telephone number, email address and the applicable RA number. You are solely responsible for all shipping and insurance costs for returning the product to Primacoustic, and you will not be reimbursed or compensated for any loss or damage incurred. Primacoustic will at its discretion repair or replace the product. Should the product be no longer available, Primacoustic reserves the right to exchange this with a product of similar performance and value. Due to different dye lots, Primacoustic cannot guarantee exact color match. This Warranty shall solely extend to the original owner and is limited to manufacturing defects only and excludes damage due to improper installation, freight handling, wear and tear, abuse, misuse, misapplication, color fading or deterioration due to prolonged exposure to ultra violet light, smoke, humidity or other environmental factors. It is understood that the use and suitability of the product is entirely the responsibility of the buyer or specifying engineer and as such, these parties agree to hold Primacoustic, or its associated company, and/or officers, harmless from any responsibility whatsoever other than what is clearly outlined in this warranty. This warranty gives you specific legal rights, and you may also have other rights, which may vary depending on where you live and where the product was purchased.



Primacoustic is a division of Radial Engineering Ltd.  
 1588 Kebet Way, Port Coquitlam, BC Canada V3C 5M5  
 Tel: 604-942-1001 • Fax: 604-942-1010 • [info@primacoustic.com](mailto:info@primacoustic.com)  
 Specifications and appearance subject to change without notice.  
 Copyright © 2015, all rights reserved.  
 User Guide part #: R870 2055 10

## ASSEMBLY WITHOUT EXTENSION BAR

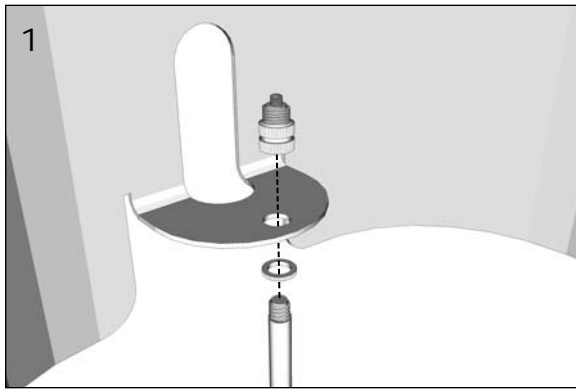

Thread the knurled ring onto the microphone stand. If your stand already has a ring or flange you can use it instead. The knurled ring is intended for stands that do not have a ring or flange.

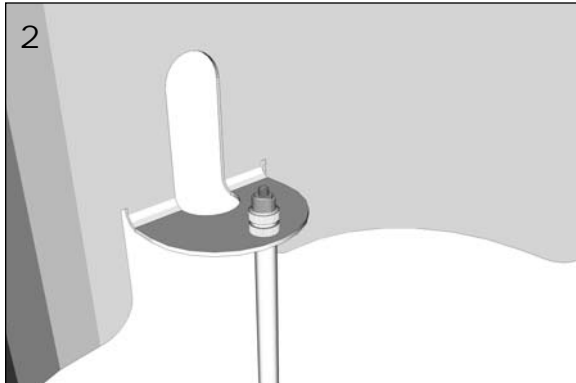

Slip the VoxGuard over the top of the microphone stand and secure it with the threaded thumbscrew. The thumbscrew locks down the VoxGuard as well as provides the microphone clip with a solid mount.

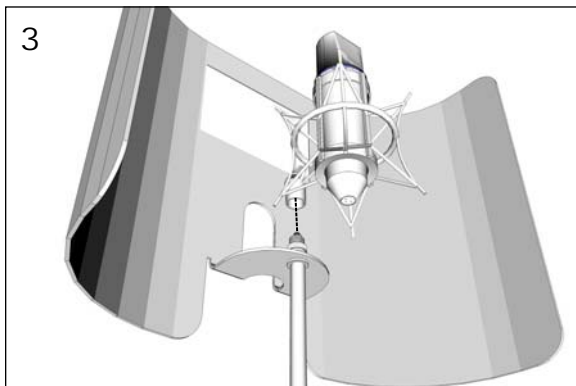

Once the ring and threaded thumbscrew are installed you can screw on the microphone shockmount or clip. Note: When using large shockmounts, hold the mount stationary while threading the stand into the mount.

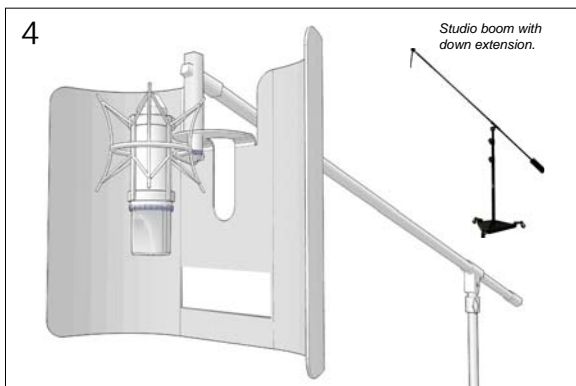

The VoxGuard may be used with a studio boom that features a down extension. Assembly is the same except the VoxGuard and mic are inverted.

## ASSEMBLY WITH EXTENSION BAR

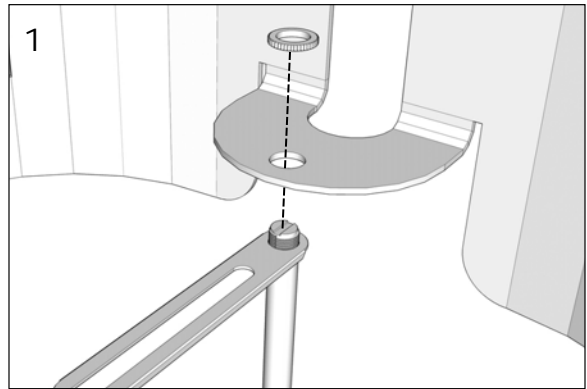

Slip the extension bar onto the stand first, followed by the VoxGuard. Secure in place using the knurled ring.

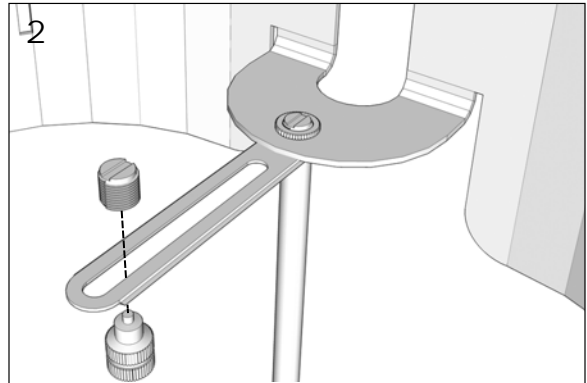

The thumbscrew passes through the extension bar and is secured on top using the threaded insert. The microphone shockmount or clip attaches to the threaded insert.

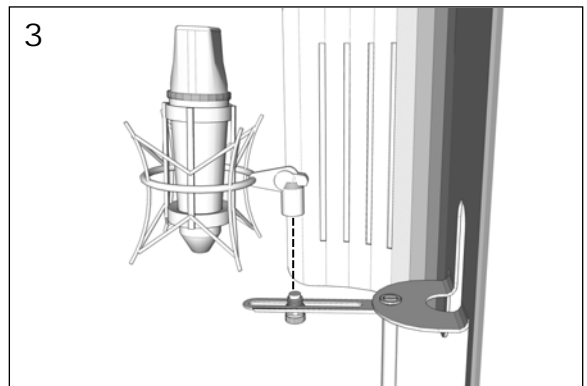

Once the threaded thumbscrew and insert are in place you can attach the microphone shockmount or clip. Changing mics does not require any disassembly. Simply remove one mic and replace.

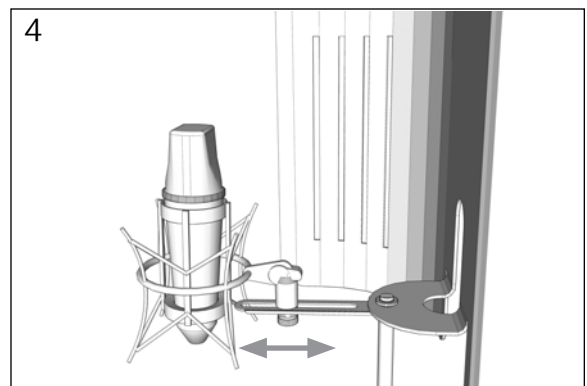

The microphone can be positioned along the extension bar to tune the amount of room ambience the mic picks up. When in place, tighten the thumbscrew while firmly holding the shockmount or clip.